

User Manual

ST16 series instruction



Please read the instruction carefully before operation.
Please keep this manual for random reference.

CONTENTS

SAFETY PRECAUTIONS	1
PLACEMENT PRECAUTIONS	2
CONNECTION PRECAUTIONS	3
NAME'S OF PARTS	4-5
NAME AND FUNCTION OF OPERATING PARTS	6-12
HEALTH PRECATUIONS	13-15
PRECAUTION BEFORE USING	16
HOW TO CLEAN PART	17
HOW TO INSTALL THE SPARE PARTS	18-19
HOW TO IHNSTALL PARTS TO THE MACHINE	20-22
HOW TO CLEAN THE MACHINE	23-24
POUR MATERAIL	25-26
DAILY OPERATION -	27-31
ONCE EVERY TWO WEEKS	32-33
MATAINANCE INSTRUCITON	34-36
PRECATIONS WILL NOT USE FOR A LONG TIME	37
PRECAUTIONS BEFORE ENTERUSTING REPAIR	38
IN CASE OF THE FOLLWING	39-42
CIRCUIT DIAGRAM	43
WARRANTY CARD	44

SAFETY PRECAUTIONS

◆ Please read and understand “Safety Precautions” carefully before operation.

◆ Please comply with the following content which are very important with safety.



◆ The meaning of the signs are as follows.

 **Warning** Using in incorrect way may lead to bad injury or death

 **Attention** Using in incorrect way may lead to thing damages or human injury

🍃 The damages involve house, family property, livestock and pets and wide range damages

Sign and Representation

	<p>▲ Represent attention(including warning) The attention content is near ▲ and show in words or sign The left sign is “Caution, electric shock”.</p>
	<p>⊘ Represent prohibition(what cannot do). The prohibition content is near ⊘ and show in words or sign The left sign is “No machine idle”.</p>
	<p>● Represent mandatory enforcement of directives (what must do). The prohibition content is near ● and show in words or sign The left sign is “Grounded”.</p>

PLACEMENT PRECAUTIONS



Warning

Please evenly and solid ground or it'll topple, be noisy or too much shake.



Place evenly

Don't put in moisture or wet place or it may lead to controller short circuit.



Prohibition

Don't use in the place with vitriol like hot spring earth or salt like near sea or bay, or it may lead to inner corrosion or trouble.



Prohibition

User Note

- Please put in well ventilated place.
- Please don't put in sun or near heating appliance.

Don't put anything on the top of the cover, or it will lead to noise.

Use the machine between 5-33°C of ambient temperature.

Keep at least 1m space for the machine, or it has bad impact on heat dissipation and capability of working.

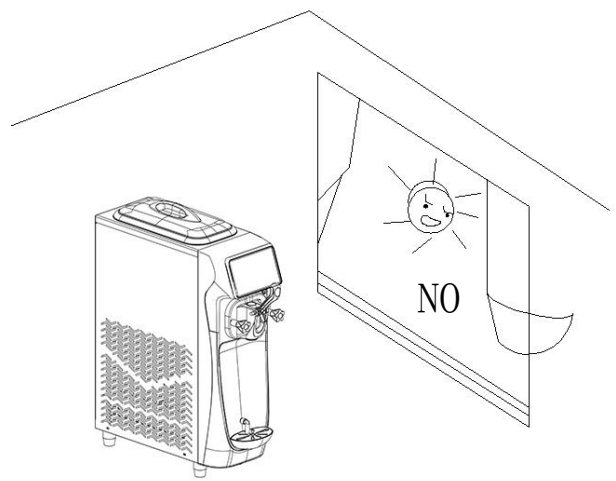
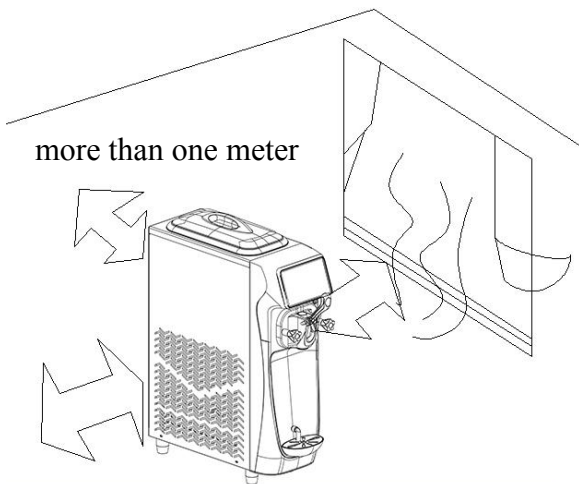

CONNECTION PRECAUTIONS



Warning

Entrust electrical construction unit to connect the ground wire, or may lead or electric shock when there's trouble or electric leakage.



Grounded

Connect the ice cream machine to a special socket(the power supply is consistent with The famous brand)



Warning

Don't damage power line, or process, gather into a bundle, stretch, bend, wrap, or the power line may be damaged and lead to fire accident.



Prohibition

User Precautions

Please entrust electrical construction unit to connect the ground wire and residual-current breaker(action current) .

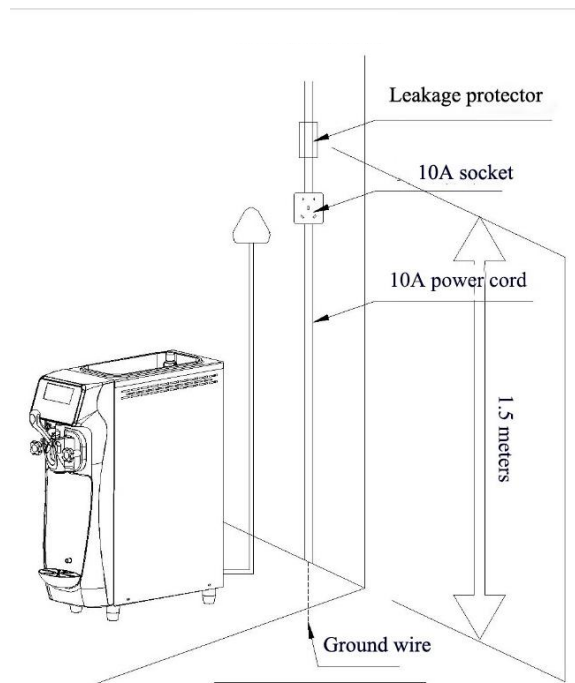

NAMES' OF PARTS

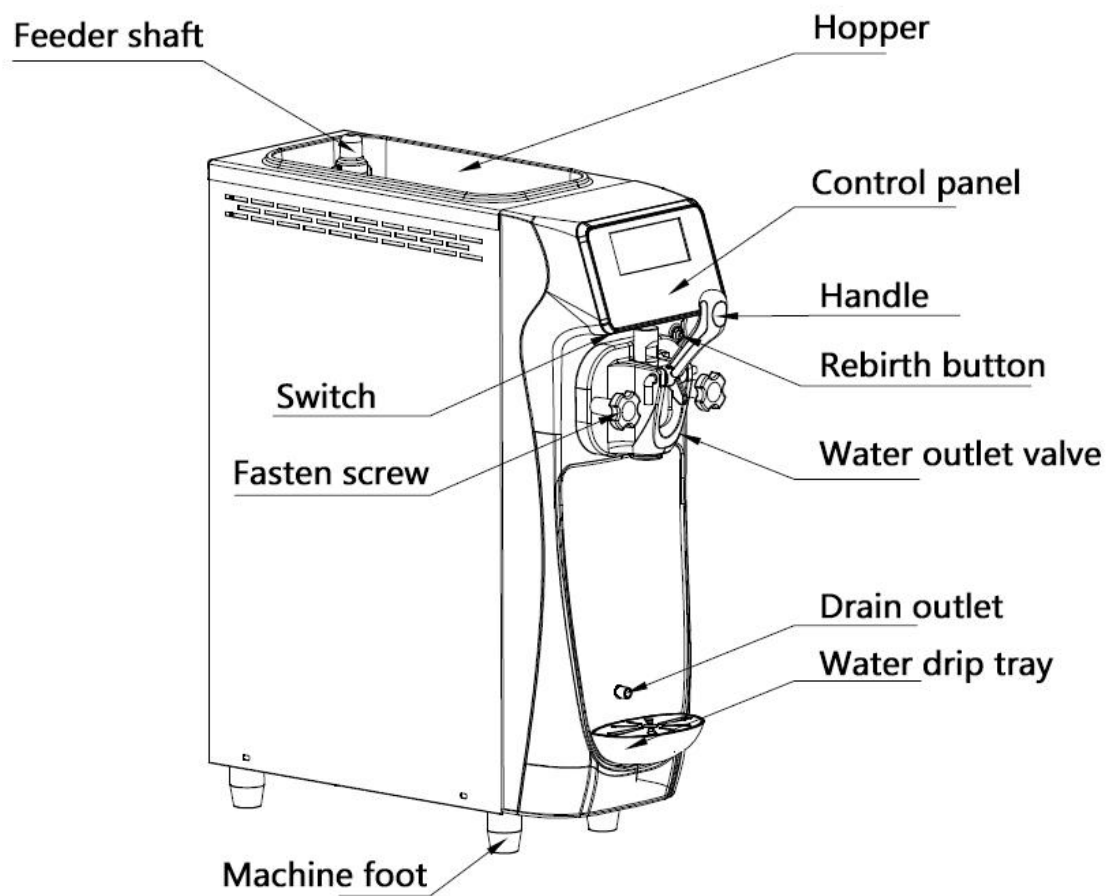

- Seals for beater 1 for free
- O seals 2 for free

- D seals 1 for free
- Vaseline 1 for free

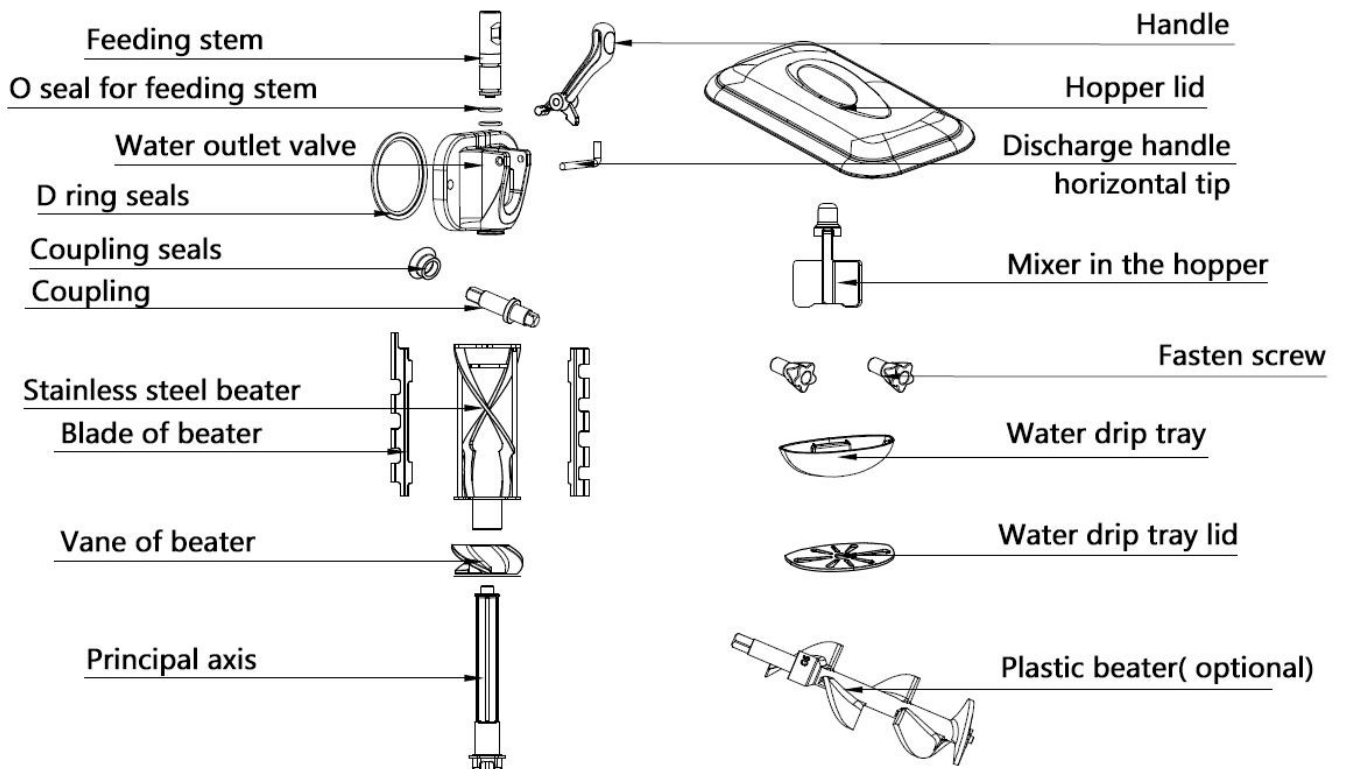

NAME AND FUNCTION OF OPERATING PARTS





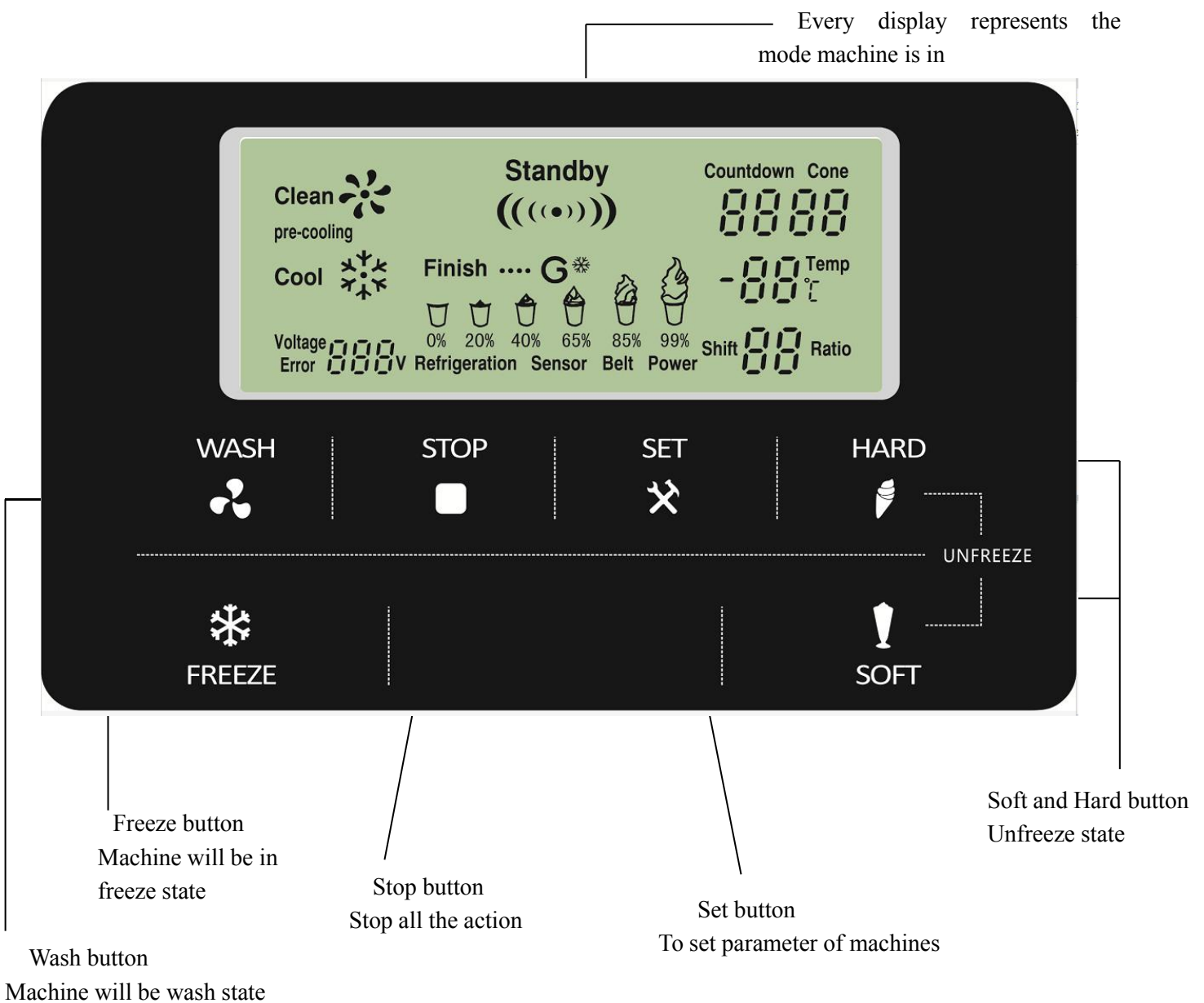

It's good when there's a “tick tack” sound when press button except for SET button.

(To prevent mistake, press button need to put forth little strength).

- Before switch to different button, press stop first.
- Safe protection function: For safety, please don't press any button without install the water outlet valve.



Detail Information of 5 inch Display

	<p>Represents machine is in clean state. Only beater in the cylinder are stirring, pour water can clean the machine.</p>
	<p>Represents machine is in standby mode. Long press SET can set parameter or others.</p>
	<p>Represents back temperature. There will be alarm when it lower than -25°C but will not impact capability of machine.</p>
	<p>Represents the ice cream number. It scores 1 time when handle jack-up and touch the micro switch. There is a “tick tack”when micro switch is touched.</p>
	<p>The number represents the time left to start freeing again after stops. During this period can be manually opened after the cooling or charge will automatically start after the cooling.</p>
	<p>At normal freezing state, it represents shape rate of material in cylinder, when it reaches to 99%, the material are all ready and machine will stop automatically after working a while. At SET state, it represents the present shift of the machine.</p>
	<p>Represents it's in freezing state. When it reaches to 99%, the material are all ready and machine will stop automatically after working a while.</p>

SET OF Parameters

In the standby mode, press "SET" for 5s , this part will show the setting for softness/Hardness.. Again press "SET" for 5s, it will show the "stop times which is set for stop times after 99% shape rate. Again press "SET" for 5s, it shows modification valve of motor rotate speed. Again press "SET" for 5s, it shows temperature for pre-cooling. Again press "SET" for 5s, it shows modification valve of lack of raw material. Again press "SET" for 5s, it's delay times for compressor to start. Again press "SET" for 5s, it's state of air pump. 1 is off, 2 is auto, 3 is on.

Hardness/softness and relative parameter setting

In the sates of setting hardness, press "hard" or "soft" can change the level. Range is 1-8. Note: If it's too hard, ice cream will not be able to put out.

In the setting state of " stop time", Press "hard" and " soft" can change times. Range is 1-15, setting is 5 minutes.

In the state of setting motor modification valve, press "hard" or "soft" can change the motor modification valve. Range is 1-16, and 8 is the first, add one number means one circle based on the actual measurement, in the contrast, is the same. It's not suggest user change this parameter, if change, please consult after-service department.

In the state of setting Temp. of pre-cooling, press "hard" or "soft" can change pre-cooling temperature. Range is 1°C—15°C, the setting is 10°C.

In the state of setting Temp. of lack of material, press "hard" or "soft" can change it. Range is -2°C—15°C, small means strong sensitivity while big means weak sensitivity.

In the state of compressor stop times, press "plus" or "minus" can change it. Range is 1-120s, the setting is 20s. The parameter is set well, please do not make any adjustments.

In the state of puffed pump, press "plus" or "minus" can change it. 1 often off: 2, automatic, 3 normally open, the setting is 2: automatic. If the material not go into the cylinder, the user can adjust 1, often off.

Detail Information of 7 inch Display



Freezing: begin to make ice cream

Play: common operation introduction

Keep Fresh: pre-cooling function of hopper, keeping material fresh

Wash: press it when need cleaning, only beater stirs

Defrosting: make the material soft and melted

Set: some settings of parameter

Refrigeration Interface

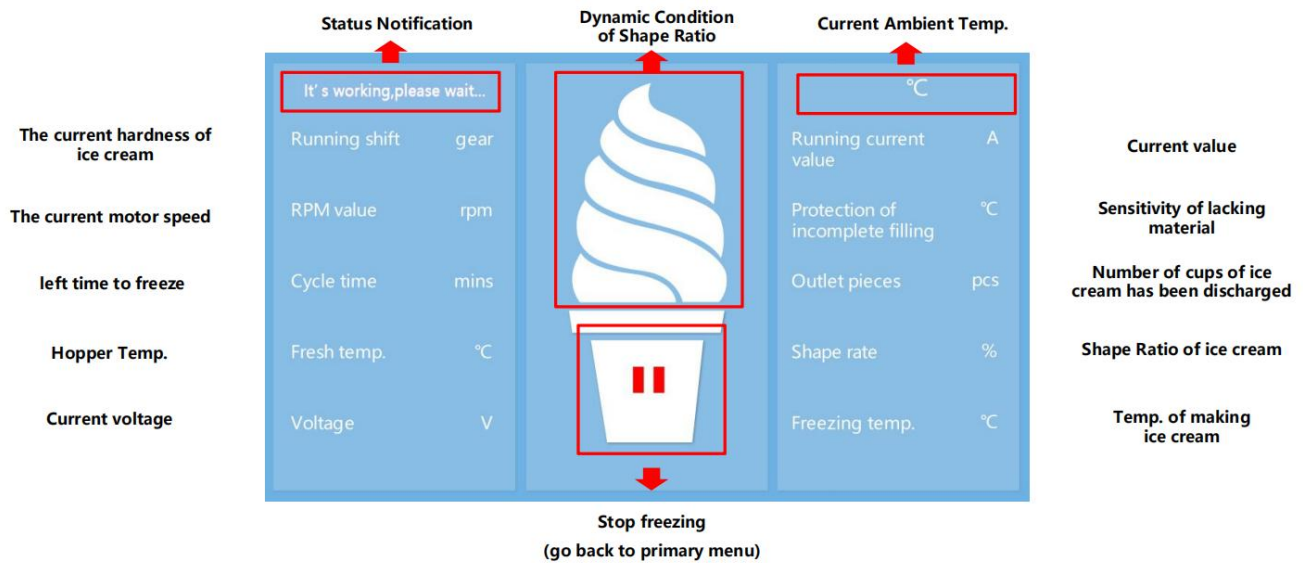

Refrigeration Interface

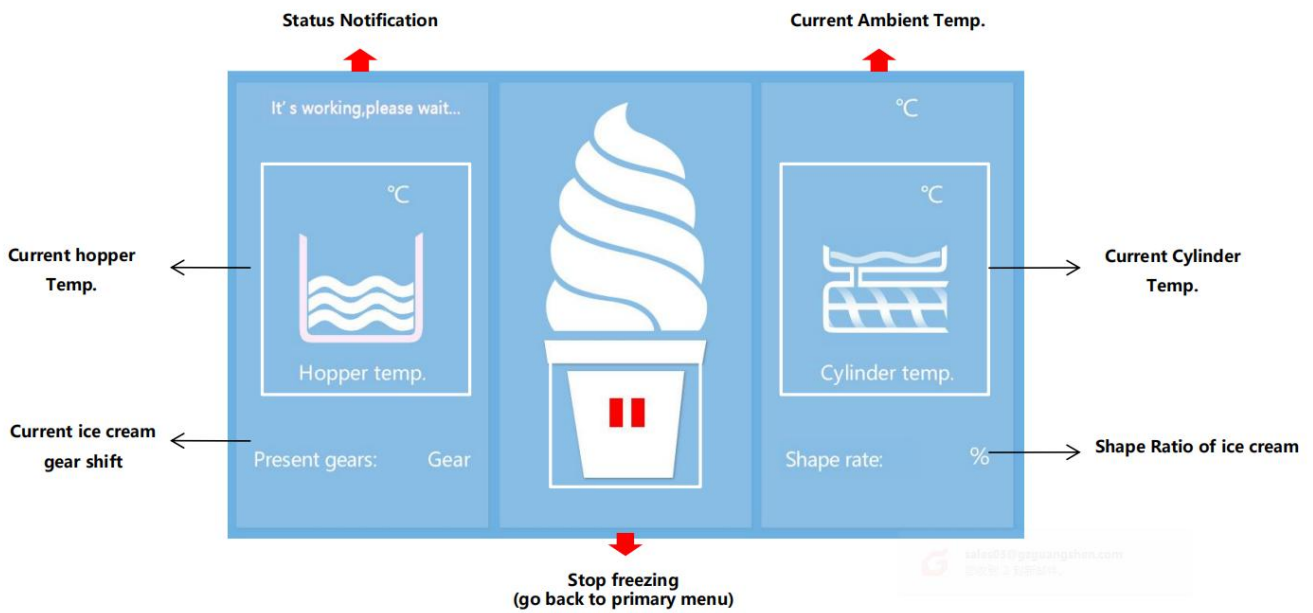

Fresh interface



The equipment enters the fresh condition and the temperature of the basin is kept at a low temperature

Defrost interface

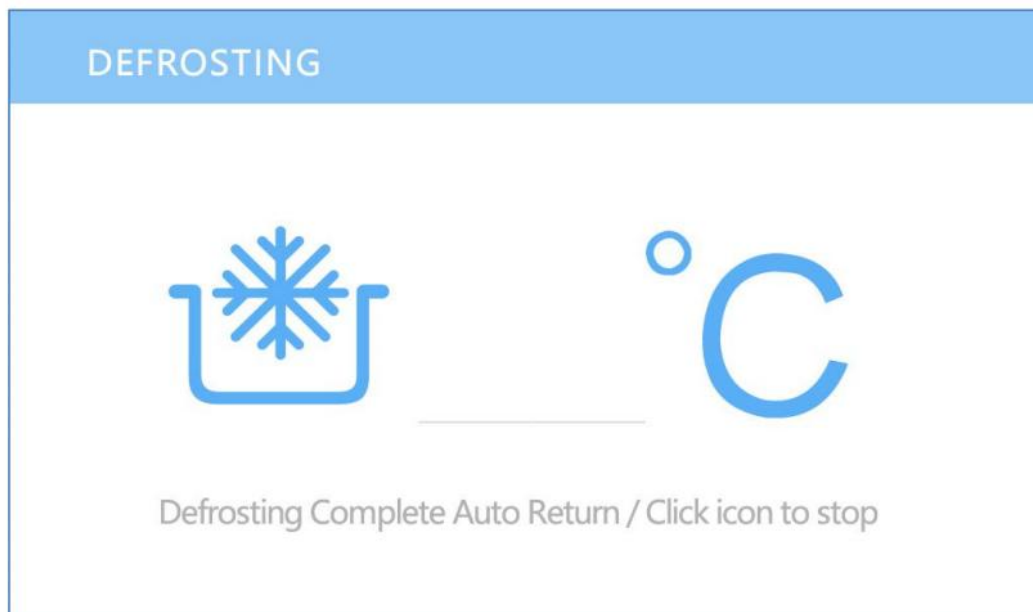

When the freezing cylinder opens, the temperature of the freezer rises , automatically returned after finishing defrost

Cleaning interface

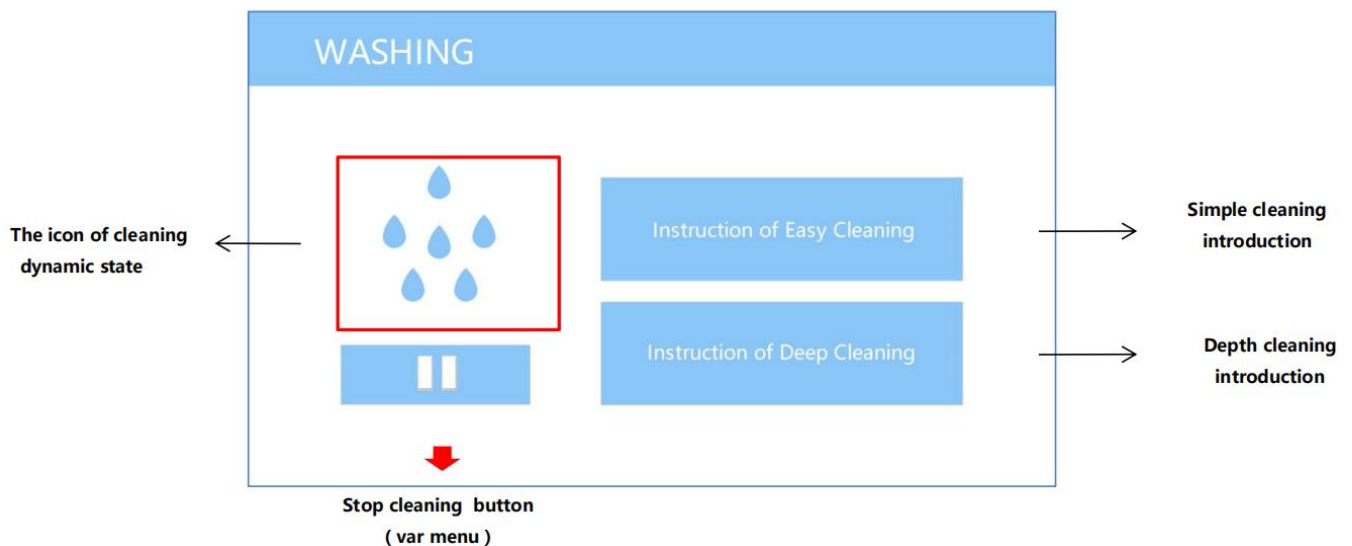

Setup interface

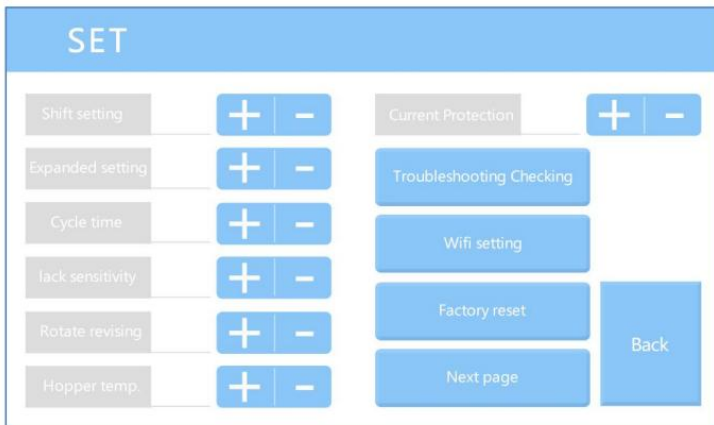

Rotate revising : no adjustment is recommended

Hopper temp.: no adjustment is recommended

Current protection: no adjustment is recommended

Troubleshooting Checking: equipment failure warning

Wifi setting: Internet of things exclusive

Factory setting: return to factory parameters

Stall settings: If the ice cream taste too soft, increase the value of some; the other hand, reduce the value of some

Expansion-setting: the degree of puffing of ice cream

Cycle time: when the refrigeration reaches 100%, the equipment enters the standby state time (not recommended adjustment)

Lack sensitivity: the feed cylinder has the material, the equipment prompts the lack of material, the numerical adjustment of the larger; There is no material in the cylinder, there is no shortage of the alarm, but the numerical adjustment is smaller;

Setup interface



Running current value: current running current value

Power consumption: how much electricity is used

Number of cups reset: the current cup number is zero

Time setting: time date setting

Power consumption/24h: how much electricity was used that day

Present cone: check the number of cups before that (When the hands pick up the top of the board and touch the internal micro-switch, it will be recorded as once)

Total cone: count the total number of ice cream equipment

Hopper protected temp.: lack of material sensitivity adjustment

Due to environment temperature, the use of raw materials, personal taste different, can be adjusted according to actual condition, the adjustment of parameters is not recommended, do not adjust (after-sales personnel according to the the cause of the problem of parameter identification equipment)

Ice Cream Health Matters

Warning

To use raw materials for hygiene, otherwise it may be hazardous to health.



To use raw materials for hygiene

Do not put the ice cream that has been taken out again in the pot. The material coming out maybe contaminated and endanger the health of the customer.



Prohibition

Be sure to sterilize every day and dismantle every two week, otherwise the bacteria may multiply.



Cleaning and disinfection

The operator must wash his hands, otherwise it may cause contamination of the materials.



Keep clean

Health Aspects of the Important Issues

◆ Discharge door

Please carefully clean the ice cream that sticks to the plastic head outlet and fully sterilize with the disinfectant.

1. Spray 3-5 times of disinfectant from the plastic head and remove the sticky ice cream.
2. Wipe clean the ice cream that sticks to the plastic head outlet with paper towel with a disinfectant.
3. Make sure that there is any remover at the outlet of plastic head, if any of the cleaning operations are repeated.
4. Spray 3-5 times again with disinfectant from the plastic head.

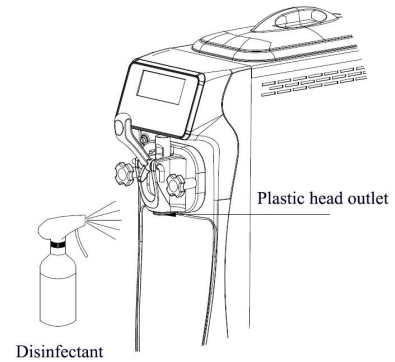

◆ Machine body

1. Be sure to disassemble and clean once every two weeks. When dismantling and cleaning, please discard all the raw materials remaining in the machine.
2. Disassemble the cleaning is good, the accessories will be assembled and then washed with hot water for five minutes to ensure sterilization.

◆ Ingredients

1. Spray disinfectant from the opening.

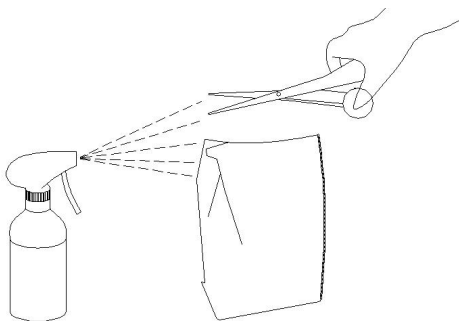

Disinfectant Ingredients

2. Please use a paper towel to clean the scissors and disinfectant on the material bag.

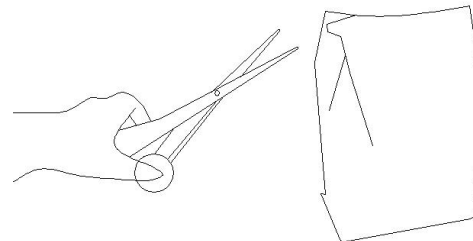

Ingredients

Hygiene of Ice Cream (continued)

◆ Quick-wear parts

- Even on the seal even if the naked eye can not see the scars, may also lead to "ice cream leakage", "sterilization" and other issues, so please take three months for the general replacement period, please replace the new product on a regular basis. Even if the replacement period, if there are injuries and other issues, please promptly replaced.

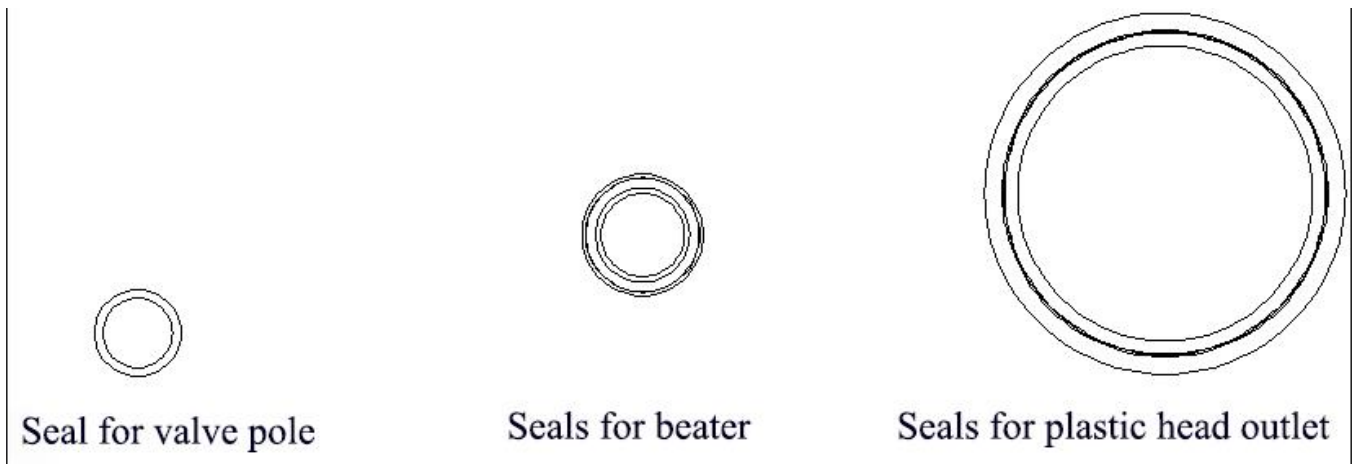

Precautions before use



No professional staff guidance shall not be commissioned. Otherwise it may cause a malfunction of the machine and a safety accident.



Prohibition

Non-maintenance personnel shall not dismantle and modify the machine. Otherwise it may cause a malfunction of the machine and a safety accident



Prohibition

When the gas leak occurs, do not touch the machine, leakage circuit breakers, and open windows ventilation. Otherwise it may cause an explosion.



For ventilation.

Do not use flammable items in the vicinity. Otherwise it may cause a fire.



Prohibition.

Do not trample and hang on the machine, place heavy objects. Doing so may damage the machine and cause injury.



Prohibition.

Do not insert your fingers or bars into the heat sink. Otherwise it may cause personal injury and affect the cooling effect.



Prohibition.

Do not touch electrical parts or switches with wet hands. Doing so may cause electric shock.



Prohibition

This machine is not intended for use by persons who are weak, unresponsive or mentally handicapped(including children), unless instructed or assisted by the guardian. Children should be supervised to ensure that they do not play the machine.



Part Cleaning Method

For the first time you use or use it for a long time, please clean the parts before use.

1 Please use food detergent and cleaning brush to clean the parts that have been dismantled.

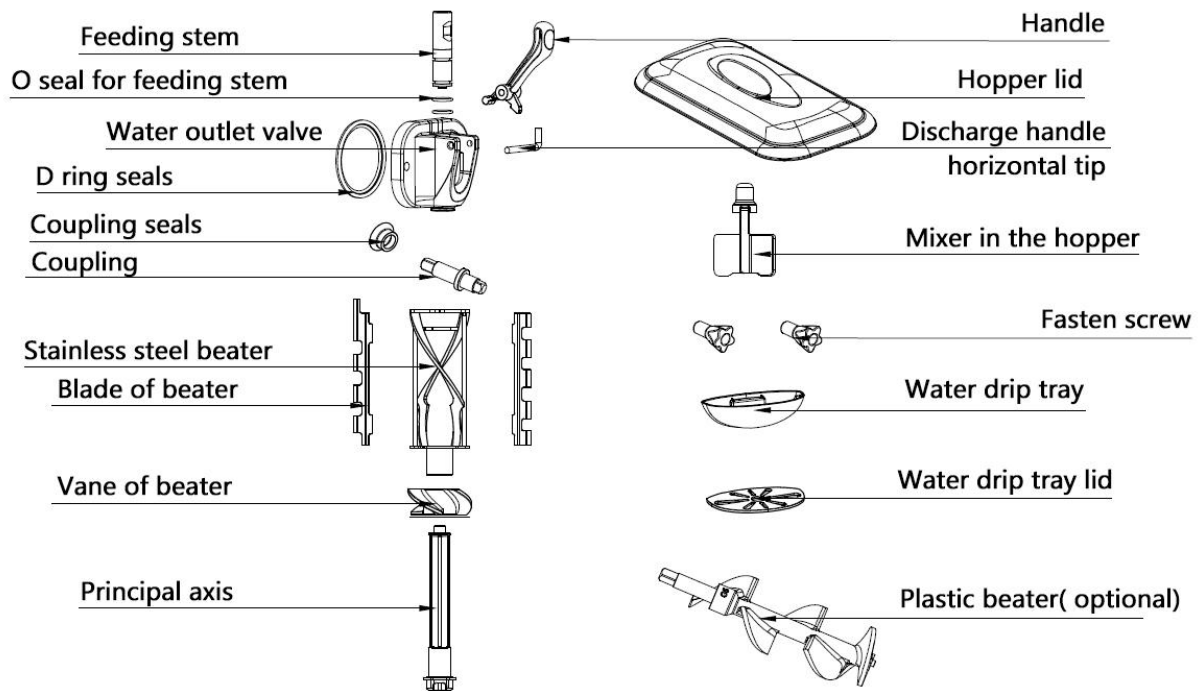

User note

- Do not damage parts or lose parts during operation
- Do not wash the resin part with hot water or dishwasher. Otherwise it may cause deformation.
- Please do not in the detergent or bactericidal solution in the bubble parts for more than 30 minutes. Otherwise it may cause deterioration.

Assembly method of parts

1.the assembly of the valve pole

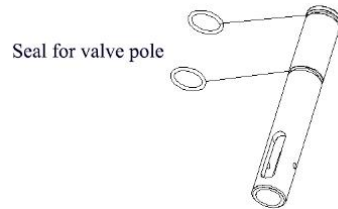

the assembly of the valve pole

1. Install O-rings and seals on the two rods, and do not need to be dismantled, such as dismantling, reassemble as shown. When assembling an I-shaped seal ring, apply for a little lubricant to the seal head.

2.Handle the assembly

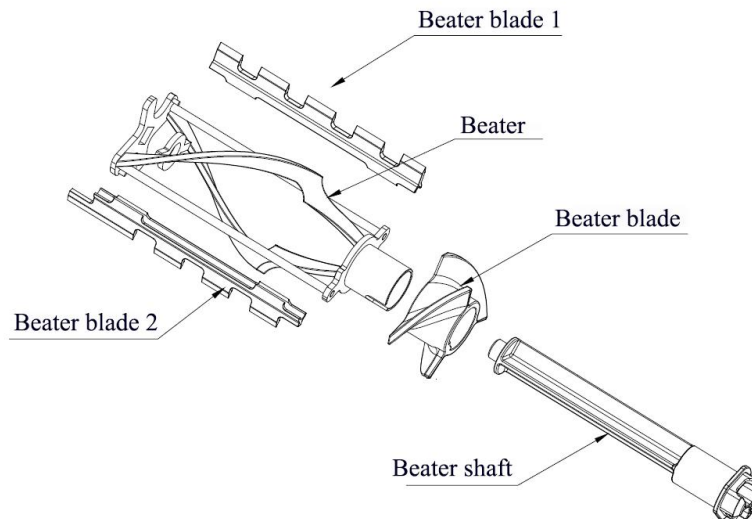

the assembly of the beater

3. The assembly of beater coupling

1. smudge vaseline to rubber parts before installing parts.
2. install coupling

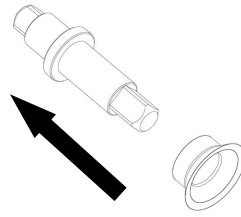

4. Discharge door assembly

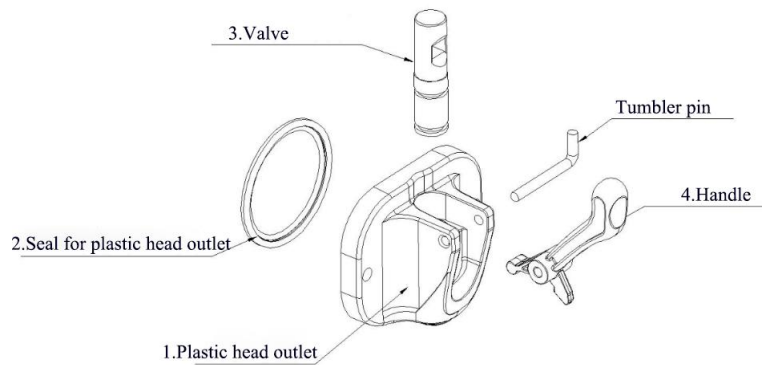

1. Insert the valve pole into the water outlet valve, and Groove direction outward (before the installation, apply Vaseline to valve pole);
2. Put the handle to groove of valve pole after installing the valve pole, and then use tumbler pin to fix it.
3. Install the D rings to water outlet valve groove.

HOW TO IHNSTALL PARTS TO THE MACHINE



Warning

When assembling and removing components, turn off the switch to control the power switch. Otherwise it may accidentally touch the start of the machine causing injury.



shut down

Operation disinfection of opponents of fingers. Otherwise it may endanger human health.



Sterilization

1. Make sure that the control power switch is turned off.

Make sure the display is off.

2. Insert the beater joint shaft into the square shaft of the reducer, and make the coupling seals close to the groove at the rear cover of the evaporator.

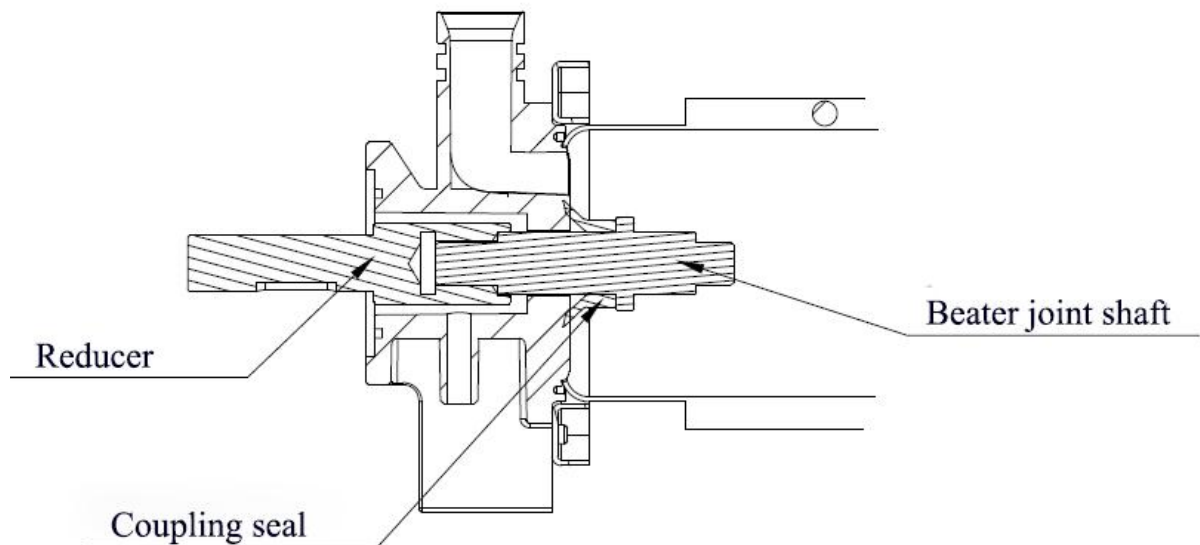

3. Insert the stirrer into the freezing cylinder and slowly rotate the stirrer into the quadrilateral interface of the gear unit.

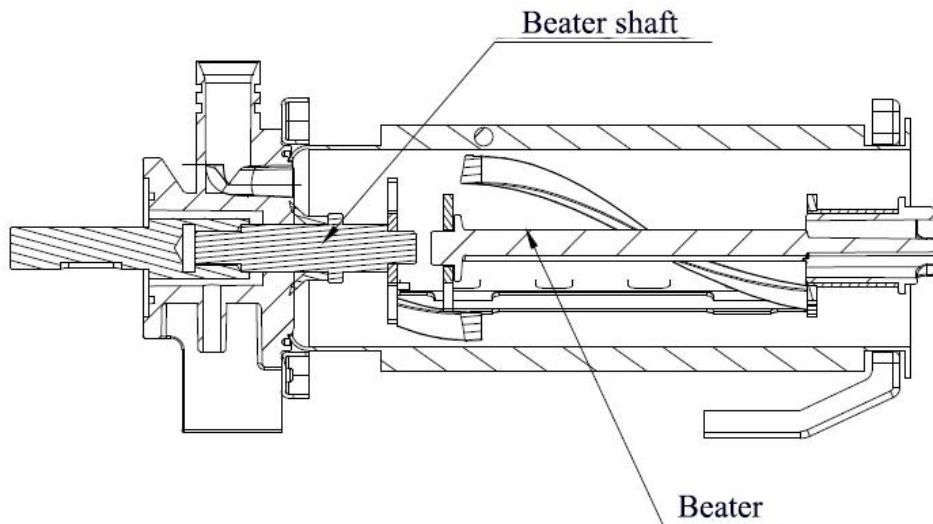

4. Insert the evaporator seal into the beater hole, pass the plastic head through the inner hole of the beater and the two plastic head screws, and twist the single-head plastic head fastening bolt clockwise to fix the plastic head.

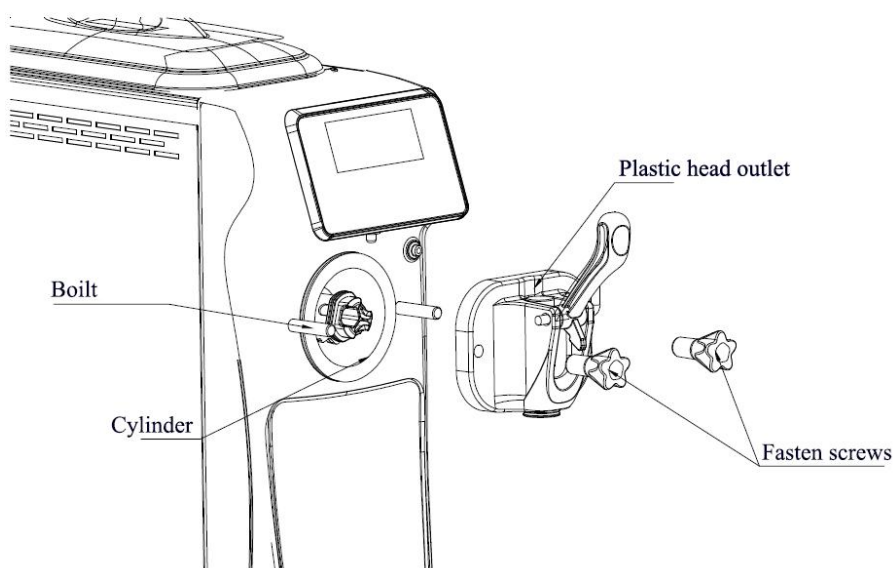

5. Put the plastic beater part to the agitator in the hopper.

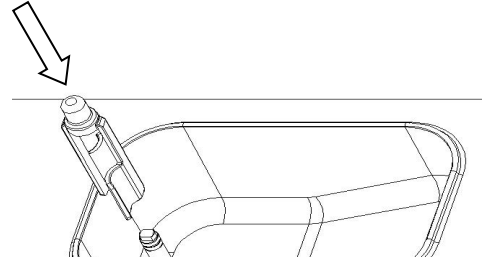

6. Install the water drip tray to the tank, and then put the water drip tray lid to the top of drip tray.

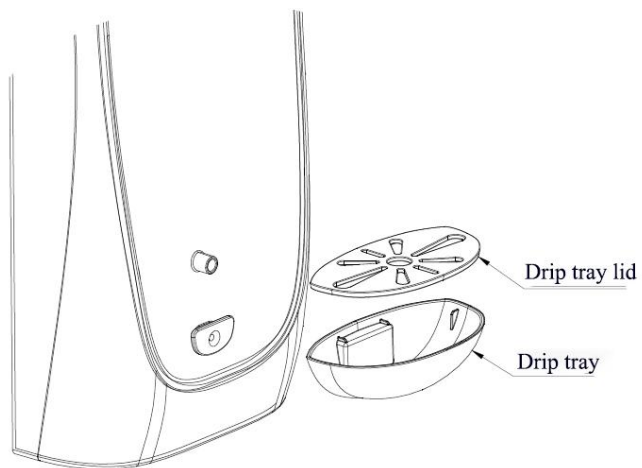

Ice cream machine cleaning method

1 Please clean parts with food detergent.

*For details, please read“page 17” .

2 Please install the clean parts on the ice cream machine.

* For details, please read “page 17-18” .

3 Please open the ice cream machine control power switch.

After opening the ice cream machine into standby.

User note

After assembly is complete, do not press any switch in the case where no water or material is present in the pot, or it may cause malfunction of the machine.

4 Please use the right amount of food detergent into the basin, and then into the pot in the amount of water, press the cleaning button, stirrer began to rotate. Wash for 3-5 minutes.

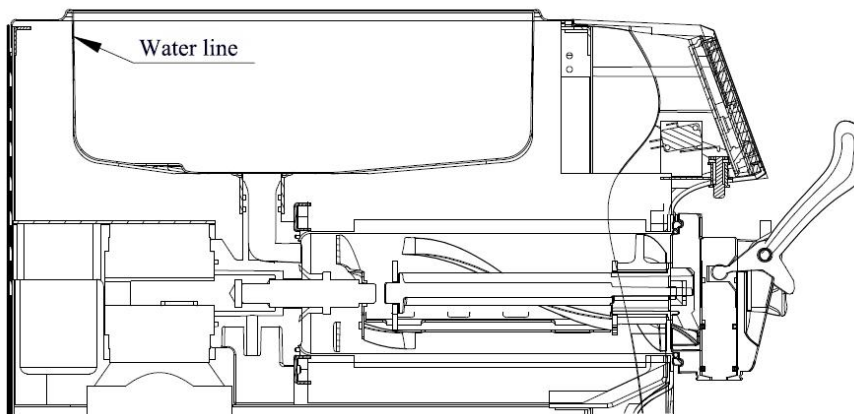



Warning

Do not let the water overflow.

Doing so may cause leakage or electric shock in the machine.



Prohibition

5 Please wash the water. After cleaning for 3-5 minutes, pull the three handles down, then catch the water with a bucket and repeat the wash for 2-4 times.(cannot be cleaned with the last washed water).

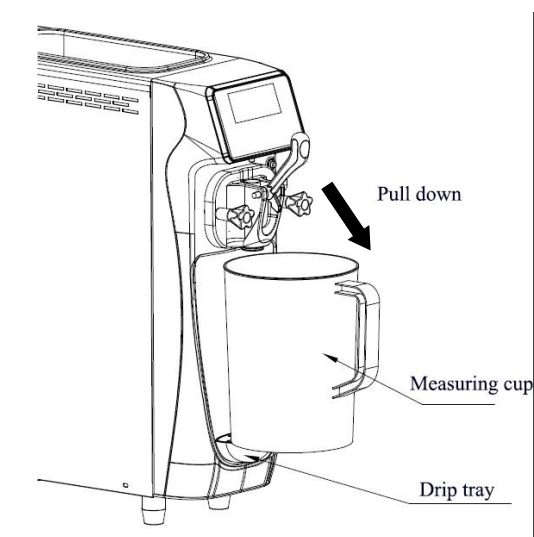

User note

Do not place the bucket in the water box, which may damage the water box.

Raw material filled



Warning

Do not put your fingers in the feedstock supply.

Doing so may result in finger injury or machine malfunction.



Prohibition



Note

Do not use the material other than ice cream raw materials.

Otherwise it may cause machine malfunction.



Prohibition

1 Prepare the right amount of raw materials.

Before adding the material, try to ensure that there is residual moisture in the freezer.

① Pull down the handle, in the state of the pick up the bar, a small of raw material into the basin.

② The outlet will be out of water, until the material flows out, please pull up the handle, hit the rod down.

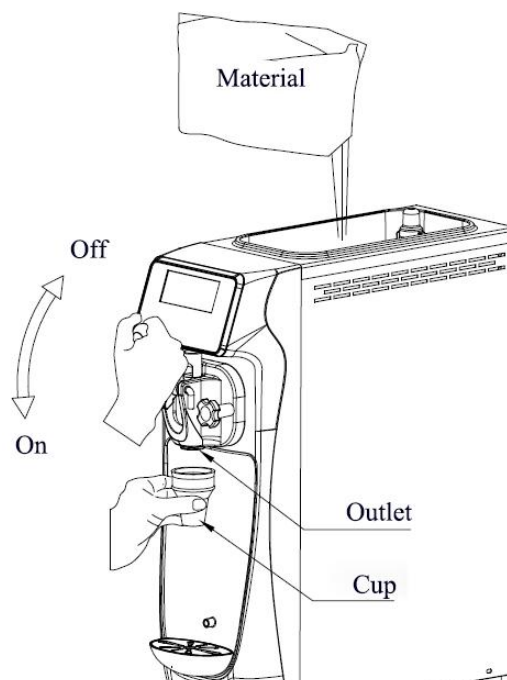

2 Pull down handle, 600cc material from measuring cup , taken out and poured back to the hopper.

Note: Please use the measuring cup that has been sterilized by washing and disinfecting solution.
Please cover the lid.

Do not add more ingredients than the top cover in the hopper.

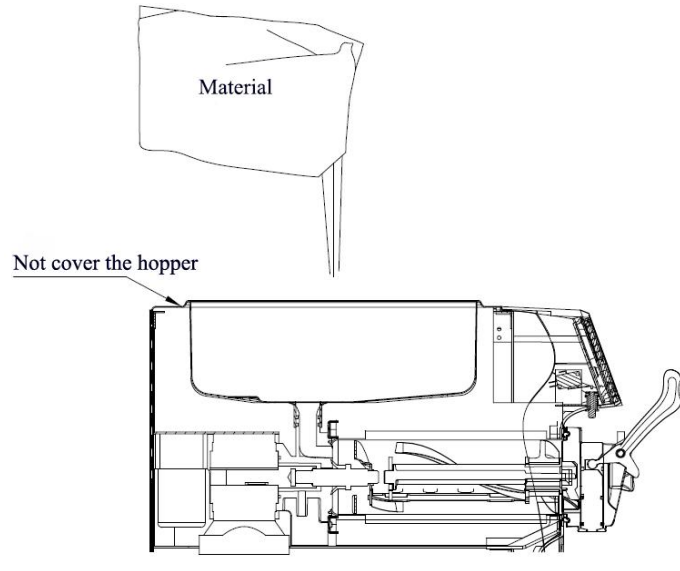

3 Make sure that the plastic water outlet head screws are loosen.

User note

Be sure to confirm that the plastic head is fixed with loose plastic screws . if loose , can cause raw material leakage.

Please cover the hopper lid

Please don't remove the handle during freezing, otherwise the material will leak out from the plastic head

Be sure to turn off the power switch when the machine not work.

DAILY OPERATION → Before

1. Please put the food detergent into the hopper with water for cleaning.

*For details, please read“page 17”.

* For details of the material, please read“page 25~26”.

Please sterilize the plastic head outlet.

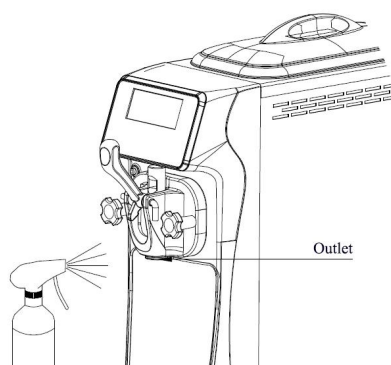

2. Make ice cream

The machine will stop automatically when the shape rate reaches 99%, that mean the ice cream have already.

Make ice cream by dropping down the handle.

DAILY OPERATION → Working



Warning

When the machine is abnormal, cut off ,stop running, otherwise it may cause an accident.



Cut off

The cylinder must be filled with material when freezing, otherwise will freeze so hard and will damage the beater.



Double hopper with material

Do not put your fingers into the feedstock. otherwise will result in finger injury or machine malfunction.



Prohibition



Note

To use material for hygiene, otherwise it may damage health.



Cut off the switch

The ice cream that has been taken out cannot be put back again, otherwise it may damage health.



Prohibition

 **If the alarm of lack of material is flashing, please add the material**

DAILY OPERATION → Working

About Puffing rate

Puffing rate refers to the air content of ice cream, is relative to the material , the ratio of the column, expressed in %. Ice cream in the cylinder during the cooling process, the volume of the expansion. Mixed with air to form a creamy state. Puffing rate is very important for the quality and shape of ice cream. After the material is injected into the ice cream machine, please adjust the position of the expansion rod.

DAILY OPERATION → After



Warning

Daily sterilization, otherwise the bacterial will bad for health.



sterilization

1 Please put all the remaining material in the cylinder out , and clean it with the water.



2 Clean the plastic head and sterilize it.

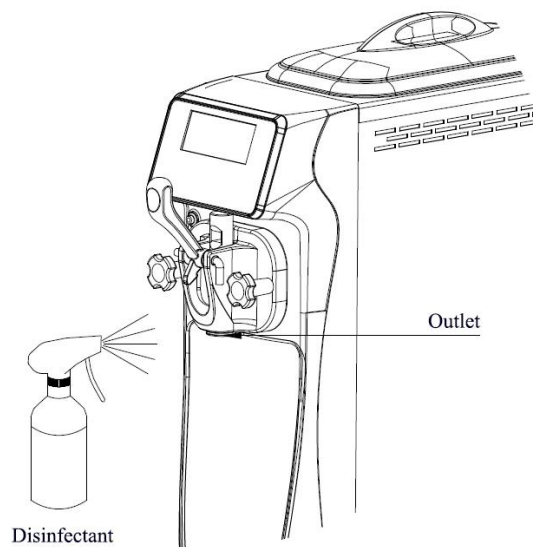

4 Please do not add the material near closing, can start pre-cooling function if have

User note

- Be sure to confirm that the plastic head is fixed with loose plastic screws . if loose , can cause raw material leakage.
- Please cover the hopper lid.
- Please don't remove the handle during freezing, otherwise the material will leak out from the plastic head.

ONE TIME EVERY TWO WEEKS



Warning

When assembling or removing parts, turn off power switch first, otherwise it may cause injury by touch the switch accidentally.



Sterilization

Do not let water out from hopper, otherwise it may damage health.



Prohibition

Dismantle and clean every two weeks, otherwise the bacterial will cause bad health.



Sterilization

Please wash the hopper with food detergent and clear cloth. Rinse 2 or 3 times.
The hopper shall be clean carefully with brush.

Every two weeks operation for the first time

Disassembly and cleaning of parts (page 13~14)

- Disassemble to the smallest.

Part installed on the machine (page 15~18)

- Turn off the power

Machine cleaning (page 19~20)

Filling of material (page 21~23)

- put the material to the hopper.

Working (page 24~30)

- Make sure the freezing is on.
- sterilize the plastic water outlet.

Disassemble and cleaning

- Discard the remaining material.
- Turn off the power.

MATAINANCE INSTRUCITON

Warning

When servicing, turn off power, otherwise it may cause injury by touch the switch accidentally.



Turn off

Do not spill water directly on the machine, it will cause electric shock.



Prohibition

Do not use the power cord if it's damaged, otherwise a short circuit may cause a fire or electric shock.



Prohibition

About Drain pipe

The drain pipe come out the chassis, if the material come out from drain pipe, it might need to replaced the corrugated ring, please replace by yourself. If any question, please contact after-sale department of technician.

1 Surface maintenance

please wipe with a dry, soft cloth. If it's serious, please clean with food detergent in warm water, wipe the dirt and the residual detergent.

The button of the machine, the base is vulnerable, please to be cleaned.

User note

- Please do not use polishing powder, gasoline, water or hot water. it will damage the outer packaging .
- Do not spill water directly on the machine, it will cause electric shock.
- Please check it 1 or 2 times a month to check if the power cord is damaged. 。

2 Consumable parts will lead to " too soft ice cream, ice cream leakage or cannot clean thoroughly" and so on.

Therefore, please replace the part on regular basis

Name	Number	Replaced period
Set of seals		
Seal for valve pole	2	3 months
D ring seals	1	
Seal for beater	1	

3 Clean the condenser

The condenser will be sticky dust and affect heat dissipation and freezing after work for a long times, (Performance: bad production or difficult to be shaped ice cream at the same times) , Please clean it once every three month (In poor environment, please clean each month) , The best is to be cleaned by professional workers, Please turn off the power before cleaning and pay to attention to condenser fins.

4 Clean the filter net.

Follow the arrow direction, and remove the filter net, then clean it thoroughly, and then reinstall the filter net in its original position.

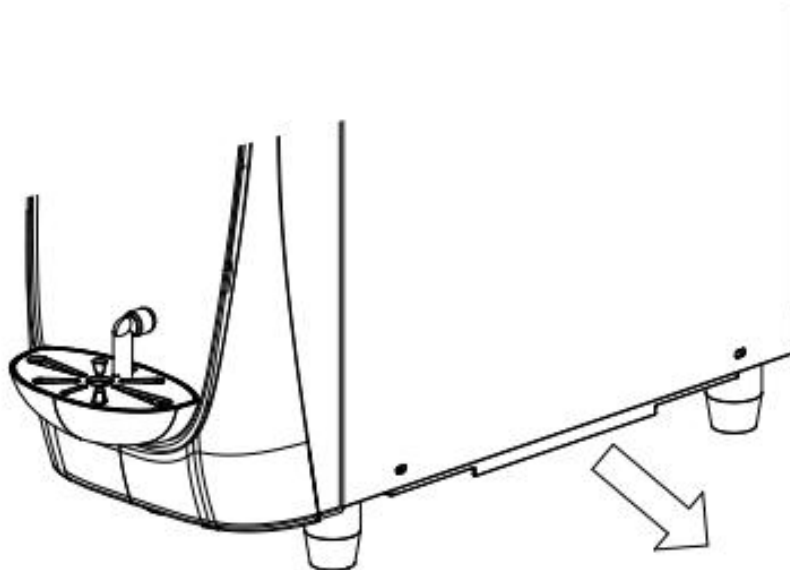

PRECAUTIONS WILL NOT USE FOR A LONG TIME



Warning

Please unplug the power when you are not using it for a long time, otherwise it may reduce the life of power cord.



Unplug the power supply



Note

Please cover the machine with plastic film when you are not using it for a long times, otherwise it may be affected by dust.



Dust-proof

Please pay attention to the drainage when temperature lower than 0°C, otherwise it may cause water leakage.



Drainage

- Please do the following when you are not using it for a long time.
Please dry the water from hopper and cylinder carefully, and then keep it by covering the hopper lid.
- Please dismantle the part to the smallest. keep the clear place, which helps to extend the life the part.

PRECAUTIONS BEFORE ENTERUSTING REPAIR

Warning

Turn off the power when the machine is abnormal, otherwise it may some wrong with the machine



Unplug the power

Non-maintenance personnel shall not be dismantled and repaired, otherwise it will cause a fire or some problem of the machine



Prohibition

The problem occurred when working, please stop and check the faults list.

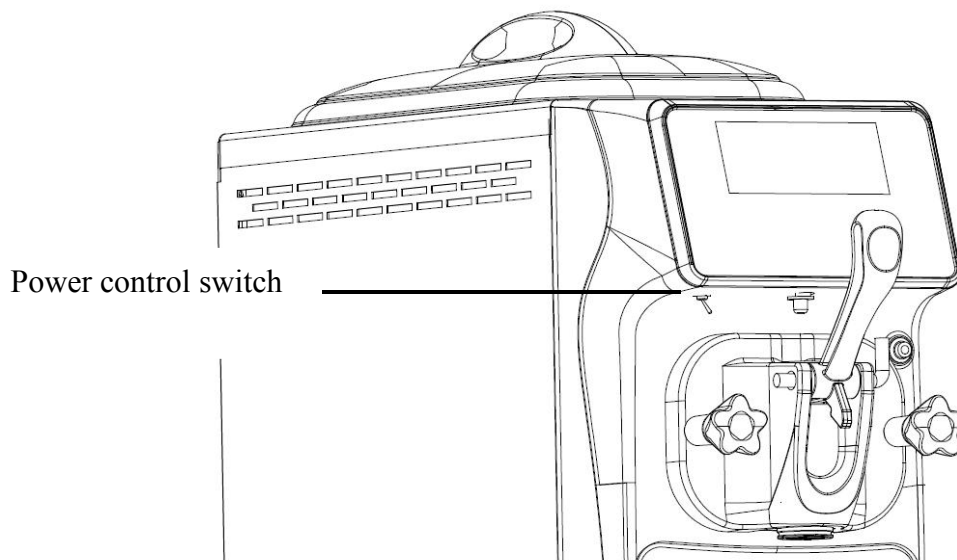

IN CASE OF THE FOLLWING(Faults and Handling)

The machine you received is control by computer program with mechanical transmission and efficient refrigeration system! You must arrange the professional staff to operate the machine and maintain it. At the same time, please know clearly about the installation and maintenance of the machine when you buy the machine , and please do the professional training before using the machine. **(Very important)**

We don't responsible for the problem caused by violating our requirement of installation and maintenance.

Meanwhile, please strictly follow the following precautions if encountered.

NO.	Problem	Probable Cause	Troubleshooting	Remarks
1	The machine doesn't work.	1. Whether power switch is powered	Open the power switch	
		2.Power line whether meet the equipment requirement	Check by professional electrician(requires more than 4 square copper core wire, and the wire can not exceed 10 meters , lower than 16A)	It is required the power load capacity cannot be lower 18`20L/4KW;32~41 L/6KW
		3. Internal wires might be bitten or loosed by the mouse	Replaced or fixed by technician	
		4.Main board problem	Contact after-sale department.	
2	Power switch trip after power on	1.Input power line or switch load is not enough	Replaced by technician	Insufficient input power cord capacity and diameter can seriously damage the machine!
		2、 Internal wires might be bitten or damaged by the mouse	Replaced by technician	
		3. High level hardness, the machine to be overloaded	Decrease the level of hardness	
		4. Unstable voltage damage the parts	Check by professional electrician	
		5. Internal short circuit of motor, circuit board or compressor	Contact after-sale department.	
3	Electric leakage	Feel electric from the body	Check if the power grounded. If no, please install the grounding wire by technician.	Handle by yourself
4	Water or material leakage from plastic water outlet.	1.D-ring is not well installed	Check the S seals whether is installed well	Handle by yourself
		2. O ring of the valve was damaged	Check the seal of valve pole whether are damaged, Please replace it if damaged	Handle by yourself
		3.fasten screw is not tightened	Tightened it	Handle by yourself
		4.Improper installation results in seal damage	Pull out vertically when disassembling. Coated Vaseline before disassembling. Do not damage the seals by sharp objects when cleaning	Handle by yourself

5	Water and material leakage residual pipe	1.Plastic water outlet is not tightened	Tightened fasten screw	
		2.Beater seals was damaged	Replaced	
		3.Seal cover of evaporator was loss	Check operating habits	
6	Abnormal noise after booting	1.Abnormal noise when cleaning	1.Larger noise when cleaning, lower after adding the material	Normal
			2., Uneven placement, self-adjusting	
			3. Loose screws on the three sides of panel	Self-tightening
			4., Motor belt is loose or tight	Adjust or replaced by technician
			5.Lubricate the reducer after work three month	Handle by technician
			6. Abnormal noisy motor mechanism	Contact us
		2.Abnormal noise when freezing	3.2.1.larger noise when lack of material, lower noise after adding the material	Normal
			3.2.2. High ice cream gear and self-adjusting	
			3.2.3. large noise of fan , handle according to 3.3	
			3.2.4. large noise of fan , handle according to 3.4	
		3.Fan noise	3.3.1.Check whether there are something around the fan blades and whether the fan bracket fixing screws are loose.	Solved by technician
			3.3.2.Whether the wind turbine leaves the shell when it rotates	Adjust the fan by technician
			3.3.3.Is the condenser fixing screw loose?	Solved by technician
		4.Motor noise	3.4.1.Motor belt noise	Adjusted or replaced the belt by technician
			3.4.2. High ice cream gear	self-adjusting
			3.4.3. Motor capacitor noise	Contact us
			3.4.4.Motor noise	
			3.4.5.Motor fixing screws loose	Adjusted by technician
		5.Compressor noise	3.5.1.Not clean condenser for a long time, condenser is too dirty, resulting in compressor overload.	cleaned by technician
			3.5.2.Internal pipe deformation cause to vibration noise	Adjusted by technician
3.5.3. Compressor noise	Contact us			
3.5.4. The compressor fixing screw is too loose or too tight	Adjusted by technician			
7	Ice cream is too soft or small capacity	1.Frequent discharge	Make ice cream after the shape rate reaches 90%	Self-debugging
		2.Small capacity model	Buy more	Contact us
		3.Incorrect formula	Adjust the water proportion	Handle by yourself
		4.Poor heat dissipation	Leave 1m space from two side	Handle by yourself
		5.Low hardness level	Adjust level	Self-debugging

		6.Unsteady voltage	Improve mains line voltage capacity of install regulator	Adjusted by technician
		7.Belt loose or damaged	Adjust or replace the belt	Adjusted by technician
		8.Bad refrigeration	Refrigerant leakage or broken compressor	Contact us
		9. Lack of material	Must ensure that the material should occupy two-thirds of the tank	
		10. Check if the voltage is normal	Adjust line or install regulator below 200V	Adjusted by technician
8	Ice cream tastes not good and with slag	1.Material not good	Improve the quality of material	Contact us
		2. Wrong proportion	Reduce water proportion properly	Self-debugging
		3.Not make ice cream for long time	Please make ice cream properly	Self-debugging
		4 Lower hardness level	Increase the level	Self-debugging
		5. Beater is damaged	Replaced	Contact us
		6.Beater is stirred so long	Please cut off the power the interval times of making ice cream so long	
9	Cannot make ice cream or too soft after stop work automatically	1. The handle not reaches enough	When the handle is not pressed down, the switch is not opened (the G letter is not flashing) and the machine does not start.	Self-debugging or check the switch by technician
		2.The first cup will soft	Start after a long times, the first cup has water so, soft is normal	Self-debugging or adjust the standby times
		3.Hardness level too high or too low	Adjust the level	Self-debugging
		4. Standby times too long	Adjust the times	Self-debugging
		5. Something wrong with the switch	Replaced	Contact us
10	Beater stuck	1. Cylinder has water, long times not operate the machine	Cause the beater swell and deform when soaking	Contact us
		2.No water or material, long time cleaning	Cause the beater swell and deform by friction	
11	Alarm of lack of material	1. The light in cylinder is shining, and there is a warning alarm sound.	Add the material	
		2. Have the material, but still have the alarm	1.Have foam material in hopper 2. with material, press clean for 5 minutes	
		3. Have alarm not reach the shape rate of 99% after adding material	Contact us or set by technician	
12	LL alarm	1.Senor problem	Check if there is a magnet on the pulley or adjust the position of the sensor or replace it.	Solved by technician
		2.Buzzer sounding, the machine stops working	Check if the sensor is misaligned or the cable is disconnected	Solved by technician
		3.The pulley is too shaken	7.3.1 Check if the pulley fixing screws are loose	Self-tightening
			7.3.2 Check the reducer whether is damaged	Contact us
13	88 alarm	1.Material shortage in cylinder	Please add in time, please restart after adding.	Self-debugging

		2. Something wrong with the beater	Larger water proportion , high hardness level	Self-debugging
		3.High ambient temperature or blocked air intake	Strengthen ventilation and remove obstacles	Self-debugging
		4. Bad refrigeration	Check if the condenser is dirty, the exhaust air is smooth, and is less refrigerant.	Contact us
14	55 alarm	1.Belt wear and slip	Adjust the belt tightness or reasonable hardness level.	Self-debugging
		2.Freezing so hard in cylinder	Reduce the water proportion or reduce hardness level	Contact us
		3 one side of reducer work, one side not work	The reducer was damaged	Contact us
		4. Motor not work or low speed	Contact us	
		5.Something wrong with the sensor or sensor connection is loose	Contact us	
15	Reaches“99%” quickly	1.Unstable voltage	Check if the voltage is right or install the regulator	Self-debugging
		2. Beater stuck	Take the beater and use after burnishing	Self-debugging
		3.Low motor speed	Check the motor whether is damaged	Contact us
16	Cannot stop automatically after reaches“99%”	1.Belt wear	Replaced	
		2., Micro switch fault	Check if the material board is not reset or the micro switch is damaged.	Self-debugging
		3. Electric main board	Replaced	Self-debugging
17	Cannot Reaches “99%”	1.Improper hardness level	Adjust the level appropriately	Contact us
		2.The ice cream formulation ratio is unreasonable	Increase water proportion	Self-debugging
		3. High ambient temperature bad ventilation, or the air intake are blocked.	In a ventilated position, clearing obstacles from air intake	Self-debugging
		4. Unstable voltage or not enough power supply capacity	Solved by technician	
		5.Bad cooling of cylinder when working without material or no frosting of the return pipe	Refrigerant leakage	Contact us
18	“HH” alarm	Compressor pressure abnormal	The condenser is too dirty or something wrong with the fan	cleaned or replaced by technician
19	“UH” alarm	Voltage over-high	Adjust voltage or increase 6KW regulator	Self-debugging
20	“UL” alarm	Voltage over-lower	Adjust voltage or increase 6KW regulator	Self-debugging
21	“RL” alarm	Temperature below - 35°C or temp. sensor break up	Check operating habits	
22	“RH” alarm	Temperature above 60°C or temp. sensor short-circuit	Check operating habits	

Meanwhile, beater, plastic water outlet, hopper, valve pole, Puffing rod is food-grade plastic part. Seals for beater, D ring seals, seals for valve pole, seals for puffing rod, grease are consumables part. And this part for free when buy the machine.

This notice is copyrighted by our company and may not be reproduced without permission. At the same time, this notice does not apply to any other branded machine.

CIRCUIT DIAGRAM

5 inch display control

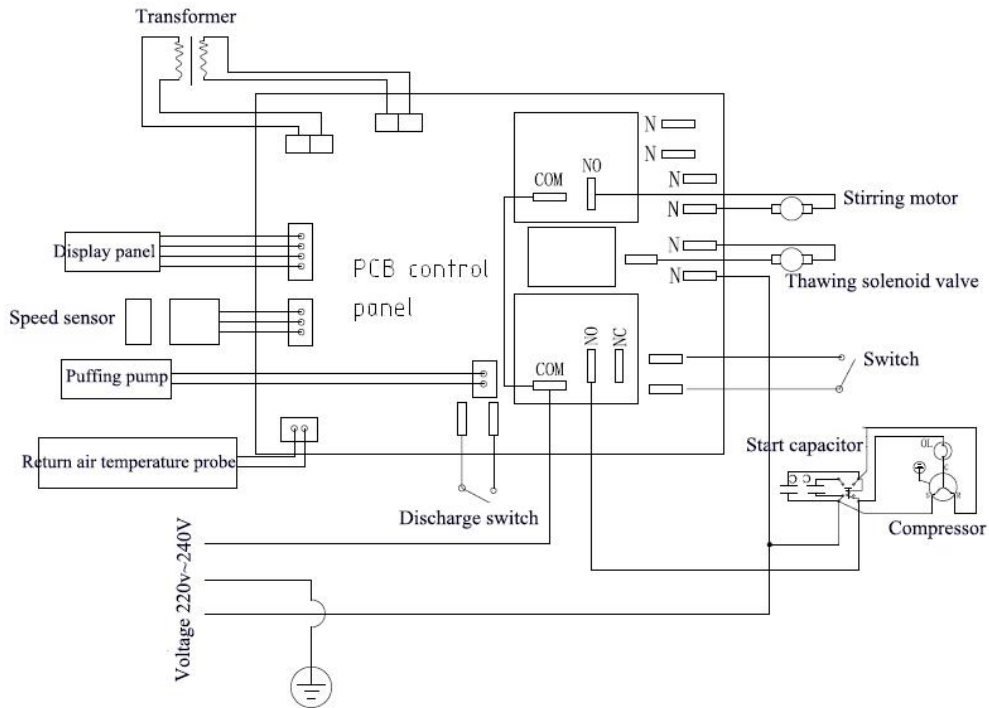

7 inch display control

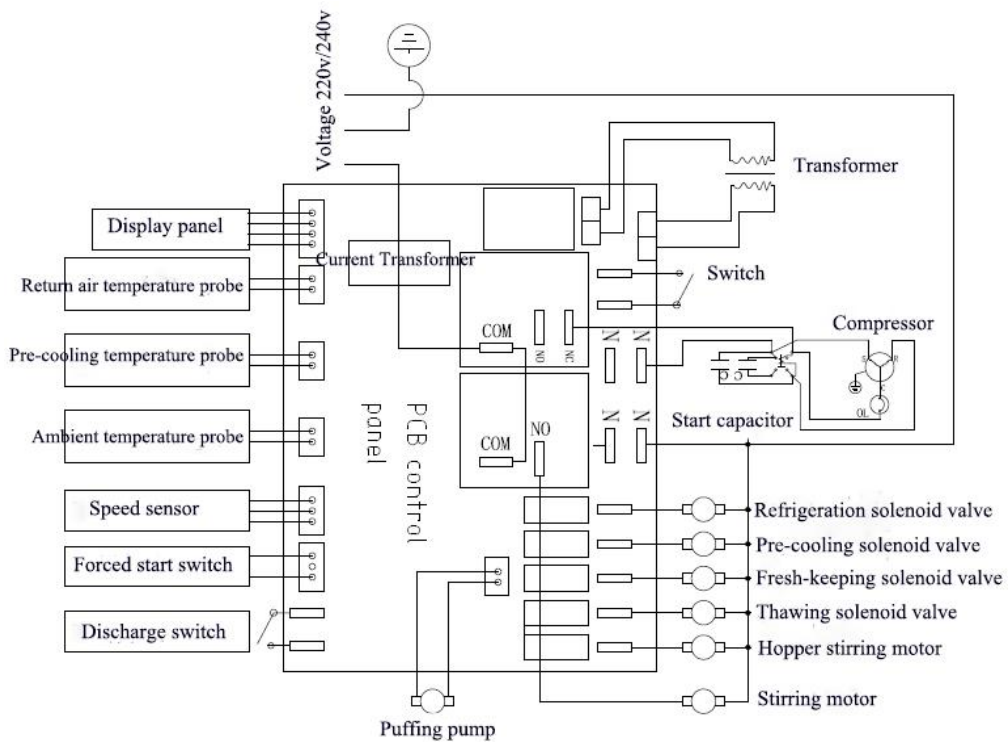

WARRANTY CARD

Sales information	User information	
Business:	User Name:	
Contact:	Model:	
Tel/Fax:	Date of purchase:	
Mobile phone:	User contact:	
User Tips: 1. Please keep and read carefully the card as soon as possible.		
2. 12 months free maintenance service from the date of purchase.		
3. Power phase is strictly prohibited, to prevent serious fault.		
4. Please check the power regularly, to ensure good connection of ground wire, to prevent the voltage from too high or too low.		
5. Keep the machine clear and in good condition and check operation from time to time		
6. We don't responsible for it due to the following acts:		
A, subject to abnormal use, improper humid environment, high temperature		
B. Unauthorized modification of misuse, abuse and error adjustment.		
7. Please contact us when the machine is abnormal.		
8. Replacement part are belong to our company.		
9. Without notice if the service terms changed.		
<p>WARRANTY CARD (COPY)</p>		
User Name:	Tel:	Model:
Address:		
Factory ID:	Date of purchase:	
Maintenance Dates:	Signature:	
Error causes and test results:		

Without notice if the manual information changed.



Save resources, protect the environment.